

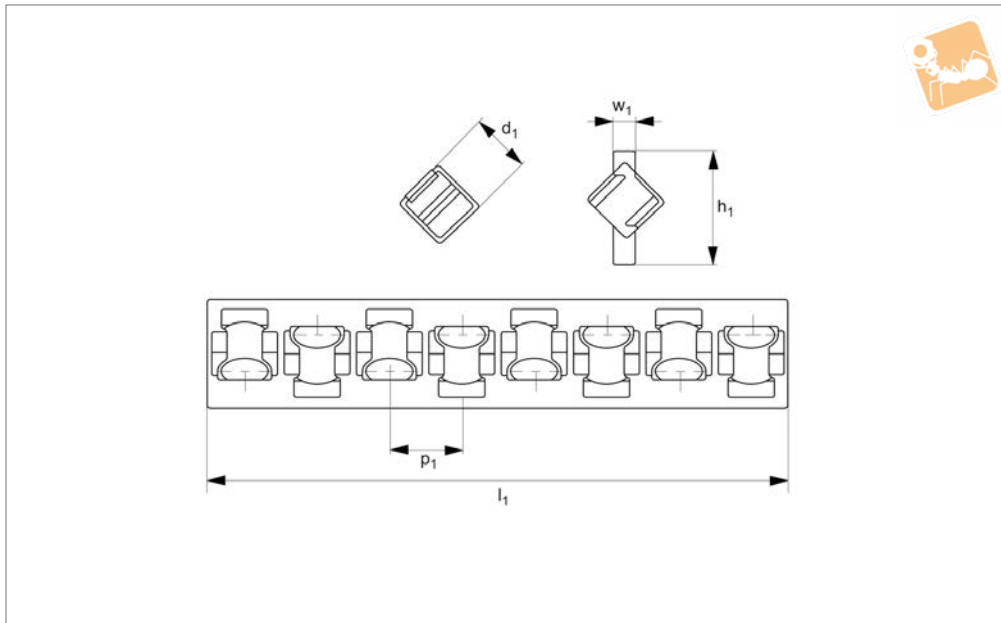

Linear Cage - Crossed Roller plastic cage

Ball & Needle Cages



L1008.020-PR

BALL & NEEDLE CAGES

Material

Steel rollers (100Cr6, class 3, hardened to 60 HRC) retaining cage plastic (PA 12).

Important Notes

For load ratings calculations the maximum recommended load is 1/3 of the max. static load.

Order No.	d_1	p_1	h_1	l_1	w_1	No. of rollers	Dyn. load C N max.
L1008.020-PR-0100	2	4	5	100	0.75	24	2040
L1008.020-PR-0200	2	4	5	200	0.75	49	4165
L1008.020-PR-0300	2	4	5	300	0.75	74	6290
L1008.020-PR-0400	2	4	5	400	0.75	99	8415
L1008.020-PR-0500	2	4	5	500	0.75	124	10540
L1008.020-PR-0600	2	4	5	600	0.75	149	12665
L1008.020-PR-0700	2	4	5	700	0.75	174	14790
L1008.020-PR-0800	2	4	5	800	0.75	199	16915
L1008.020-PR-0900	2	4	5	900	0.75	224	19040
L1008.020-PR-1000	2	4	5	1000	0.75	249	21165