

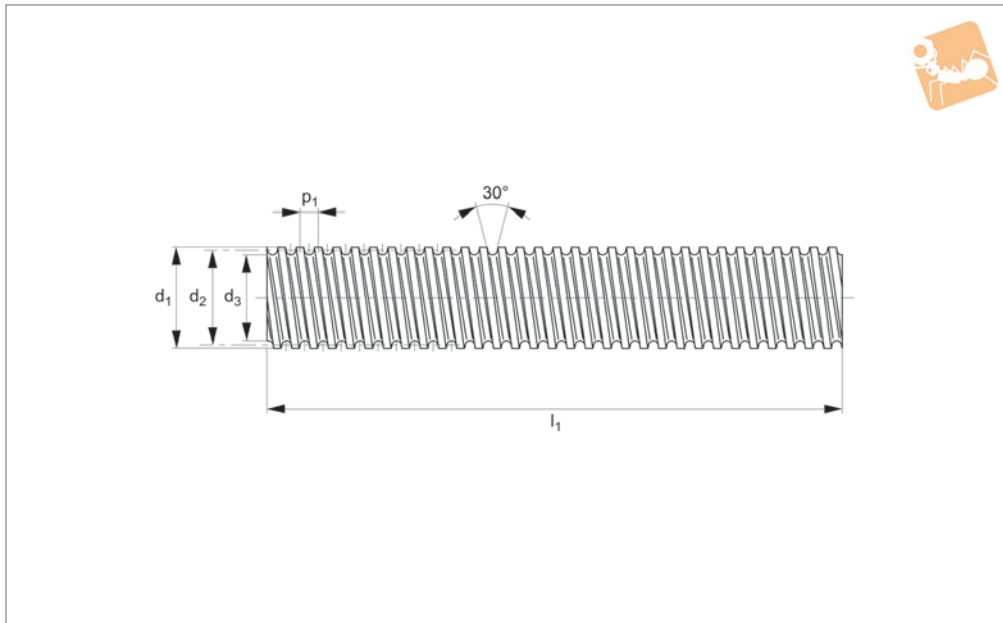

# Stainless 304 Lead Screws

left hand thread

## Lead Screws & Nuts



### L1326

LEAD SCREWS & NUTS

#### Material

Rolled trapezoidal thread, stainless steel (AISI 304, A2). Manufactured to ISO 2901/2093, DIN103.

screw. Select a suitable lead screw nut (part nos. L1330 to L1343) to suit the lead screw - the most popular nuts are the flanged, bronze nuts part no. L1331.

threads in stainless steel see part no. L1325. Cutting to required length and machining of ends - on request. Lead screw lengths of up to 6 metres can be provided for a diameter >30mm.

#### Technical Notes

„Lead“ refers to the distance that a nut will travel for a complete revolution of the

#### Tips

These are stainless steel left hand thread lead screws. For the standard right hand

Order No.	Size	No. of starts	$d_1$ tol, 7e	Lead	$p_1$	$d_2$ tol, 7e	$d_2$ tol, 7e	$d_3$ tol, 7h	$d_3$ tol, 7h	Weight kg
L1326.L08-015-1.0	TR08x1.5	1	08	1.5	1.5	7.013	7.183	5.763	7.200	0.311
L1326.L08-015-1.5	TR08x1.5	1	08	1.5	1.5	7.013	7.183	5.763	7.200	0.466
L1326.L08-015-2.0	TR08x1.5	1	08	1.5	1.5	7.013	7.183	5.763	7.200	0.622
L1326.L08-015-3.0	TR08x1.5	1	08	1.5	1.5	7.013	7.183	5.763	7.200	0.933
L1326.L10-020-1.0	TR10x2.0	1	10	2.0	2.0	8.739	8.929	6.962	7.500	0.482
L1326.L10-020-1.5	TR10x2.0	1	10	2.0	2.0	8.739	8.929	6.962	7.500	0.723
L1326.L10-020-2.0	TR10x2.0	1	10	2.0	2.0	8.739	8.929	6.962	7.500	0.964
L1326.L10-020-3.0	TR10x2.0	1	10	2.0	2.0	8.739	8.929	6.962	7.500	1.446
L1326.L12-03-1.0	TR12x3.0	1	12	3.0	3.0	10.191	10.415	7.685	8.500	0.650
L1326.L12-03-1.5	TR12x3.0	1	12	3.0	3.0	10.191	10.415	7.685	8.500	0.970
L1326.L12-03-2.0	TR12x3.0	1	12	3.0	3.0	10.191	10.415	7.685	8.500	1.300
L1326.L12-03-3.0	TR12x3.0	1	12	3.0	3.0	10.191	10.415	7.685	8.500	1.950
L1326.L16-04-1.0	TR16x4.0	1	16	4.0	4.0	13.640	13.905	10.474	11.500	1.170
L1326.L16-04-1.5	TR16x4.0	1	16	4.0	4.0	13.640	13.905	10.474	11.500	1.750
L1326.L16-04-2.0	TR16x4.0	1	16	4.0	4.0	13.640	13.905	10.474	11.500	2.340
L1326.L16-04-3.0	TR16x4.0	1	16	4.0	4.0	13.640	13.905	10.474	11.500	3.510
L1326.L20-04-1.0	TR20x4.0	1	20	4.0	4.0	17.640	17.905	14.474	15.500	1.940
L1326.L20-04-1.5	TR20x4.0	1	20	4.0	4.0	17.640	17.905	14.474	15.500	2.910
L1326.L20-04-2.0	TR20x4.0	1	20	4.0	4.0	17.640	17.905	14.474	15.500	3.880
L1326.L20-04-3.0	TR20x4.0	1	20	4.0	4.0	17.640	17.905	14.474	15.500	5.820
L1326.L24-05-1.0	TR24x5.0	1	24	5.0	5.0	21.094	21.394	17.269	18.500	2.780
L1326.L24-05-1.5	TR24x5.0	1	24	5.0	5.0	21.094	21.394	17.269	18.500	4.170
L1326.L24-05-2.0	TR24x5.0	1	24	5.0	5.0	21.094	21.394	17.269	18.500	5.560
L1326.L24-05-3.0	TR24x5.0	1	24	5.0	5.0	21.094	21.394	17.269	18.500	8.340
L1326.L28-050-1.0	TR28x5.0	1	28	5.0	5.0	25.094	25.394	21.375	22.500	3.905
L1326.L28-050-1.5	TR28x5.0	1	28	5.0	5.0	25.094	25.394	21.375	22.500	5.857
L1326.L28-050-2.0	TR28x5.0	1	28	5.0	5.0	25.094	25.394	21.375	22.500	7.810
L1326.L28-050-3.0	TR28x5.0	1	28	5.0	5.0	25.094	25.394	21.375	22.500	11.715
L1326.L30-06-1.0	TR30x6.0	1	30	6.0	6.0	26.547	26.882	21.563	23.000	4.350
L1326.L30-06-1.5	TR30x6.0	1	30	6.0	6.0	26.547	26.882	21.563	23.000	6.520



Order No.	Size	No. of starts	d <sub>1</sub> tol, 7e	Lead	p <sub>1</sub>	d <sub>2</sub> tol, 7e	d <sub>2</sub> tol, 7e	d <sub>3</sub> tol, 7h	d <sub>3</sub> tol, 7h	Weight kg
L1326.L30-06-2.0	TR30x6.0	1	30	6.0	6.0	26.547	26.882	21.563	23.000	8.700
L1326.L30-06-3.0	TR30x6.0	1	30	6.0	6.0	26.547	26.882	21.563	23.000	13.050
L1326.L32-06-1.0	TR32x6.0	1	32	6.0	6.0	28.547	28.882	23.563	25.000	5.030
L1326.L32-06-1.5	TR32x6.0	1	32	6.0	6.0	28.547	28.882	23.563	25.000	7.540
L1326.L32-06-2.0	TR32x6.0	1	32	6.0	6.0	28.547	28.882	23.563	25.000	10.060
L1326.L32-06-3.0	TR32x6.0	1	32	6.0	6.0	28.547	28.882	23.563	25.000	15.090
L1326.L36-06-1.0	TR36x6.0	1	36	6.0	6.0	32.547	32.882	27.563	29.000	6.540
L1326.L36-06-1.5	TR36x6.0	1	36	6.0	6.0	32.547	32.882	27.563	29.000	9.810
L1326.L36-06-2.0	TR36x6.0	1	36	6.0	6.0	32.547	32.882	27.563	29.000	13.080
L1326.L36-06-3.0	TR36x6.0	1	36	6.0	6.0	32.547	32.882	27.563	29.000	19.620
L1326.L40-07-1.0	TR40x7.0	1	40	7.0	7.0	36.020	36.375	30.381	32.000	7.980
L1326.L40-07-1.5	TR40x7.0	1	40	7.0	7.0	36.020	36.375	30.381	32.000	11.970
L1326.L40-07-2.0	TR40x7.0	1	40	7.0	7.0	36.020	36.375	30.381	32.000	15.960
L1326.L40-07-3.0	TR40x7.0	1	40	7.0	7.0	36.020	36.375	30.381	32.000	23.940

Order No.	l <sub>1</sub>	Lead angle	Pitch accuracy mm/300mm	Straightness mm/300mm
L1326.L08-015-1.0	1000	3°50'	0.3	0.40
L1326.L08-015-1.5	1500	3°50'	0.3	0.40
L1326.L08-015-2.0	2000	3°50'	0.3	0.40
L1326.L08-015-3.0	3000	3°50'	0.3	0.40
L1326.L10-020-1.0	1000	4°07'	0.3	0.40
L1326.L10-020-1.5	1500	4°07'	0.3	0.40
L1326.L10-020-2.0	2000	4°07'	0.3	0.40
L1326.L10-020-3.0	3000	4°07'	0.3	0.40
L1326.L12-03-1.0	1000	5°17'	0.3	0.50
L1326.L12-03-1.5	1500	5°17'	0.3	0.50
L1326.L12-03-2.0	2000	5°17'	0.3	0.50
L1326.L12-03-3.0	3000	5°17'	0.3	0.50
L1326.L16-04-1.0	1000	5°16'	0.5	0.10
L1326.L16-04-1.5	1500	5°16'	0.5	0.10
L1326.L16-04-2.0	2000	5°16'	0.5	0.10
L1326.L16-04-3.0	3000	5°16'	0.5	0.10
L1326.L20-04-1.0	1000	4°05'	0.5	0.10
L1326.L20-04-1.5	1500	4°05'	0.5	0.10
L1326.L20-04-2.0	2000	4°05'	0.5	0.10
L1326.L20-04-3.0	3000	4°05'	0.5	0.10
L1326.L24-05-1.0	1000	4°17'	0.5	0.10
L1326.L24-05-1.5	1500	4°17'	0.5	0.10
L1326.L24-05-2.0	2000	4°17'	0.5	0.10
L1326.L24-05-3.0	3000	4°17'	0.5	0.10
L1326.L28-050-1.0	1000	3°36'	0.5	0.20
L1326.L28-050-1.5	1500	3°36'	0.5	0.20
L1326.L28-050-2.0	2000	3°36'	0.5	0.20
L1326.L28-050-3.0	3000	3°36'	0.5	0.20
L1326.L30-06-1.0	1000	4°05'	0.5	0.10
L1326.L30-06-1.5	1500	4°05'	0.5	0.10
L1326.L30-06-2.0	2000	4°05'	0.5	0.10
L1326.L30-06-3.0	3000	4°05'	0.5	0.10
L1326.L32-06-1.0	1000	3°48'	0.5	0.10
L1326.L32-06-1.5	1500	3°48'	0.5	0.10
L1326.L32-06-2.0	2000	3°48'	0.5	0.10
L1326.L32-06-3.0	3000	3°48'	0.5	0.10
L1326.L36-06-1.0	1000	3°20'	0.5	0.10
L1326.L36-06-1.5	1500	3°20'	0.5	0.10
L1326.L36-06-2.0	2000	3°20'	0.5	0.10
L1326.L36-06-3.0	3000	3°20'	0.5	0.10
L1326.L40-07-1.0	1000	3°31'	0.5	0.15
L1326.L40-07-1.5	1500	3°31'	0.5	0.15
L1326.L40-07-2.0	2000	3°31'	0.5	0.15
L1326.L40-07-3.0	3000	3°31'	0.5	0.15



The choice between different types of lead screws and lead screw nuts available is generally made after taking into account the following factors.

### Choice of the screw

#### Working environment

For work environments where there are no particular corrosive or oxidising agents our steel (L1320 and L1321) lead screws can be used.

Where these conditions are not met, we recommend using our stainless steel screws (L1322 and L1323) which are particularly suitable in the following cases:

- With a relative humidity of 70-80% and above.
- Immersed in water (including sea water).
- In the presence of particular corrosive agents such as chlorides. In case of highly corrosive agents please contact our Technical Department.
- In the food industry or pharmaceutical industry, where they are used with stainless steel or bronze nuts.
- Where the lead screws cannot be reached for lubrication. In particular, for lubricating "maintenance free" fittings they are coupled with plastic nuts.
- Where working temperatures are relatively high (above 200°C) - because stainless steel has a structure that is more suited to higher temperatures.

#### Backdrive

Irreversibility defines how much the nut can "backdrive" down the lead screw. If a nut cannot backdrive down the screw then it is irreversible. This is especially important if the lead screw and nut are being used in a vertical application i.e. in this situation no backdrive is normally acceptable.

Lead screws with a lead angle of  $<2^\circ$  are completely irreversible i.e., they cannot backdrive.

Lead screws with a lead angle  $>5^\circ$  but  $<6^\circ$  still have a good degree of irreversibility and may in some instances exhibit some backdrive.

Lead screws with a lead angle  $>6^\circ$  have zero irreversibility, therefore the nut may backdrive down the lead screw with little or no load applied.

This is important to know in vertical applications.

### Choice of the nut

#### Working environment

Our bronze and stainless steel 303 lead screw nuts, are resistant to standard oxidizing agents that occur in various applications.

Where corrosive agents are present, please contact our Technical Department for advice.

**In applications where the presence of added lubricant (grease or oil) is not allowed we recommend the use of self-lubricating plastic nuts.**

**The use of plastics can however be limited by the specific working conditions, therefore please consult our Technical Department should you wish. This is because plastics have excellent self-lubrication features, but at the same time have restrictions on the working temperature or moisture absorption problems, (as well as some mechanical properties that may not be suitable for the intended use).**



### Single start and double start

#### Pitch

The axial distance between threads. Pitch is equal to the lead in a single start screw.

#### Lead

The axial distance the nut advances in one revolution of the screw. The lead is equal to the pitch times the number of starts.

$$\text{Lead} = \text{Pitch} \times \text{No. of starts}$$

For example: A 10mm diameter lead screw has a pitch of 2mm. On a single start lead screw the lead is also 2mm. On a twin start lead screw the lead is 4mm.

#### Screw starts

The number of independent threads on the screw shaft, example one or two.

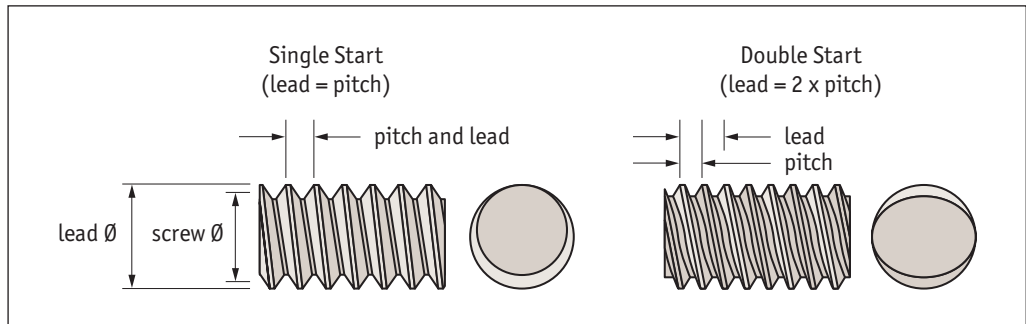

### Straightness

Automation Components lead screws are produced with controlled straightness.

Screw straightness is checked by measuring the variation of the deflection  $f$ , when the screw is supported at the ends on two fixed points and slightly rotated.

For example, the screw L1320.R30-06 has a straightness of 0.2 mm over 300 mm.

This means that a screw 30x6 300 mm long resting on two fixed points at the ends and rotated slightly displays a camber variation  $\Delta f$  less than 0.2 mm at all points on the screw.

#### Straightness

$\Delta f$  = lead screw weight camber.

Good screw straightness gives operation with load always centred on the axis, hence uniform distribution of surface contact pressure between screw and nut. This allows smooth running and a regular rotation.

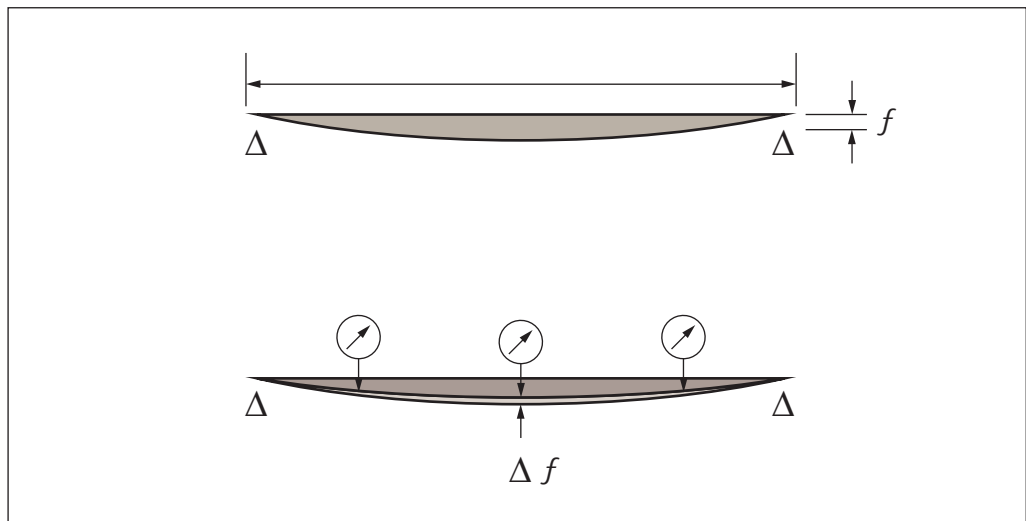



To select the correct size of lead screw and nut to use, please take into consideration the following three points:

1. The size required to minimise the wear of the nut due to friction.
2. The maximum load the screw can take before it bends.
3. The maximum rpm the screw can run at before it begins to vibrate.

### Finding a size to minimise the wear of a nut

Due to friction between the lead screw and nut, some of the power put into the lead screw is lost as heat. The solution is to limit the contact surface area between the lead screw and nut as this will help reduce the amount of friction and wear on the nut.

Lead screws are used to convert rotary motion into linear motion.

The efficiency of a lead screw and nut is defined as the amount of power you get from the nut in relation to the amount of power you put into the lead screw to begin with.

For example,  $P_t$  (the power you put into the screw) divided by  $P_u$  (the power you get from the nut) = the efficiency.

The efficiency depends on the friction between the contact surfaces of the lead screw and nut, and the lead angle of the thread.

The speed the nut moves along the lead screw must also be taken into consideration in order to limit the amount of friction in the system.

Please see the formulae on the next page which help in calculating the speeds in your application.

### Calculation of the Contact Surface Pressure p

The contact surface pressure p is calculated using the following formula.

$$p = \frac{F}{A_t}$$

F = Axial Force (N)

$A_t$  = Contact Surface Area (mm<sup>2</sup>)

For standard nuts each  $A_t$  value has been listed in the product tables



### Calculating of the sliding speed $V_{st}$

The sliding speed is the result of the speed at which the nut moves and the friction.

Calculating the sliding speed helps you to calculate the required rpm of a screw if you know what speed the nut must move at, or help to calculate how fast the nut will move if you know the rpm of the screw.

You must first find the sliding speed of your lead screw and nut using one of the below formulae and then use this to calculate either rpm or output speed of the nut.

The sliding speed is calculated using one of the following formulae.

If the rpm of the screw has already been defined:

$$V_{st} = \frac{n \cdot P}{1000 \cdot \sin \alpha}$$

$V_{st}$  = sliding speed on mean diameter (m/min)

$n$  = rpm

$P$  = thread pitch (mm)

$\alpha$  = thread helix angle

If you have already established at which speed the nut must move:

$$V_{st} = \frac{V_{tr}}{\sin \alpha}$$

$V_{st}$  = sliding speed on mean diameter (m/min)

$V_{tr}$  = motion speed (m/min)

$\alpha$  = thread helix angle

Please note that the rpm and the speed at which the nut moves are bounded as follows:

$$n \text{ (rpm)} = \frac{1000 \cdot V_{tr}}{P}$$

$n$  = rpm

$V_{tr}$  = speed at which the nut moves (m/min)

$P$  = thread pitch (mm)